

## Removing Old Cone or Vane

See Figure 2 for identification of all items referenced.

### For Fan Arrangements 1, 4, 9 and 10:

1. Shut off fan and lock out electrical power.
2. Remove inlet screens if applicable.
- 3a. **For Removing Old Inlet Cone** — Loosen fasteners at periphery of inlet cone and remove old cone.
- 3b. **For Pre-1981 Style Inlet Vane Removal** — Remove hardware from old vane which attaches it to the housing. Remove control link and old inlet vane.
- 3c. **For Post-1981 Style Inlet Vane Removal** — Remove nut (item 14) and pull connecting arm out of the way. Loosen fasteners which hold inlet vane to the fan housing, and remove old inlet vane.

### For Arrangements 3 and 7:

1. Shut off fan and lock out electric power.
2. Remove inlet screens if applicable. Release belt tension.
3. Clean and remove rust from sections of fan shaft which extend through fan inlet bearings. File smooth any burrs. Remove bearing bolts and raise shaft enough to take weight off bearing.
4. Working through fan outlet or through access door, block under periphery of fan wheel so that fan housing supports the fan wheel.
- 5a. **For Fan With Setscrew Locking Collars** — Loosen setscrews in fan inlet bearing. Using wedges or pry bars, slide bearing off end of shaft. If it is necessary to force bearing, use a brass rod to drive against inner race of bearing only.
- 5b. **For Fans With Split Type Bearing** — Remove bearing cap, bearing housing and bearing insert off end of shaft. If the bearing insert must be removed by inexperienced personnel, it is recommended that the bearing manufacturer be contacted to provide instructions for dismounting.
- 6a. **For New Installation** — Loosen fasteners which hold inlet cone and bearing support frame to the fan housing side. Remove old inlet cone and bearing support frame.
- 6b. **For Pre-1981 Style Replacement** — Remove hardware from old vane which attaches it to the housing side. Remove control arm (or drive link). Loosen fasteners which hold the inlet cone and bearing support frame to the housing side, then remove old inlet vane and bearing support frame.
- 6c. **For Post-1981 Style Replacement** — Remove nut (item 14) and pull connecting arm out of the way. Loosen fasteners which hold the inlet vane and bearing support frame to the housing side, and remove the inlet vane and bearing support frame.

Figure 1. BC, BAF, BCS Fan With Nested Inlet

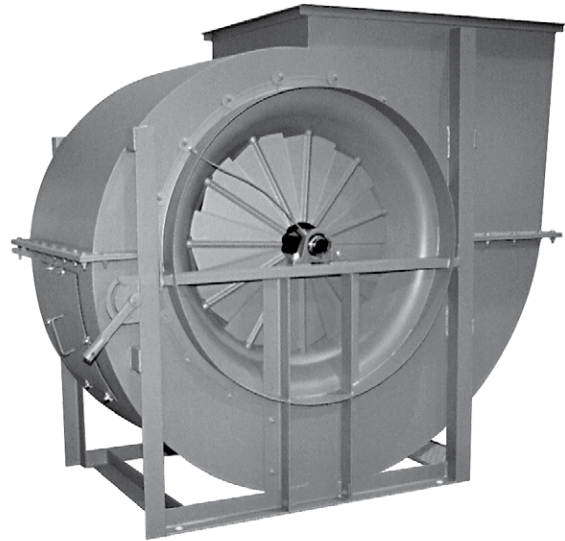

## Assembling Nested Inlet Vane

### For Fan Arrangements 1, 4, 9 & 10:

1. Using Figure 2 as a guide, assemble items 5 through 15 to the inlet vane. Threaded linkage rod (item 6) may have to be cut to required length.
2. Center inlet vane in location of old vane or cone, and rotate until inlet vane control ring is approximately in the same position as shown in Figure 3. If old control linkage is being reused, locate control ring clip so that connecting link can be reattached. Be sure that when vane is partially closed the entering air will be spun in the direction of wheel rotation.
3. For installation of new quadrant, using the dimensions in Figure 4, position quadrant (item 2 or 2A) to the housing side. Drill a hole in the fan housing side to match outside diameter of control rod housing (item 4).
4. Weld quadrant (item 2 or 2A) to housing frame (or housing side).
5. Assemble the remaining parts of control system according to Figure 2. Adjust position of connecting links as required to allow the vane to open and close smoothly.
6. Weld threaded linkage housing to hex nuts (item 12). Spot weld the control rod to vane handle and control linkage bar.

## For Arrangements 3 & 7:

- Using Figure 2 as a guide, assemble items 5 through 15 to the inlet vane. Threaded linkage rod (item 6) may have to be cut to required length.
- Center inlet vane in location of old vane or cone, and rotate until inlet vane control ring is approximately in the same position as shown in Figure 3. If old control linkage is being reused, locate control ring clip so that connecting link can be reattached.
- For installation of new quadrant, using the dimensions in Figure 4, position quadrant (item 2 or 2A) to the housing side. Drill a hole in the fan housing side to match outside diameter of control rod housing (item 4).
- Weld quadrant (item 2 or 2A) to housing frame (or housing side).
- Reassemble bearing support frame and bolt it to the fan housing as shown in Figure 5.
- Reassemble bearing and tighten bearing fasteners
- Remove blocking under wheel and check to be sure wheel turns freely. Adjust bearing position or inlet vane position as required.
- Assemble the remaining parts of control system according to Figure 2. Adjust position of connecting links as required to allow the vane to open and close smoothly.
- Weld threaded linkage housing to hex nuts (item 12). Spot weld the control rod to vane handle and control linkage bar.

Figure 2. Nested Inlet Vane Control System for SWSI BC, BAF, BCS Fans

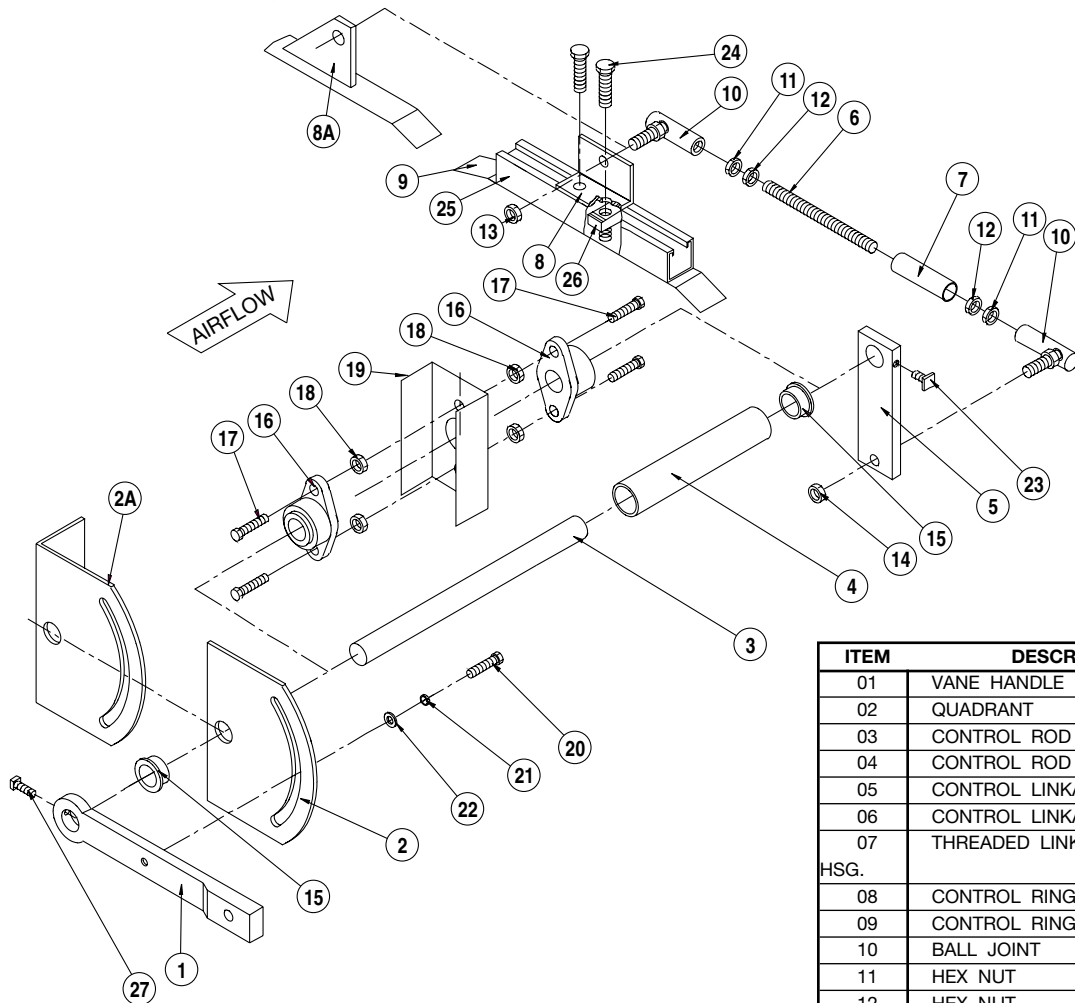

ITEM	DESCRIPTION
01	VANE HANDLE
02	QUADRANT
03	CONTROL ROD
04	CONTROL ROD HOUSING
05	CONTROL LINKAGE BAR
06	CONTROL LINKAGE ROD
07	THREADED LINKAGE ROD
HSG.	
08	CONTROL RING CLIP
09	CONTROL RING
10	BALL JOINT
11	HEX NUT
12	HEX NUT
13	HEX NUT
14	HEX NUT
15	OILITE BEARING
16	FLANGE BEARING
17	HEX BOLT
18	NEX NUT
19	BEARING BRACKET
20	HEX HEAD SCREW
21	SPRING LOCK WASHER
22	FLAT WASHER
23	SQUARE HEAD SETSCREW
24	HEX HEAD SCREW
25	UNISTRUT
26	UNISTRUT CLAMPING NUT
27	SQUARE HEAD SETSCREW

### NOTES:

- Items 16, 17, 18, 19 used for 1.5" and larger dia. control rod.
- Items 4, 15 used for .75" to 1.25" dia. control rod.
- Items 24, 25, 26 used for fan sizes 245-890.
- Item 2A used for rotatable housing design.
- Item 8A used for fan sizes 165-222.
- Item 19, bearing bracket, shall be welded to inside of the fan housing.
- Item 2, quadrant for nonrotatable fan, shall be welded on fan housing frame.
- Item 2A, quadrant for rotatable fan, shall be welded on fan housing.
- Measure threaded linkage rod length to fit.

Figure 3. Control Ring Position

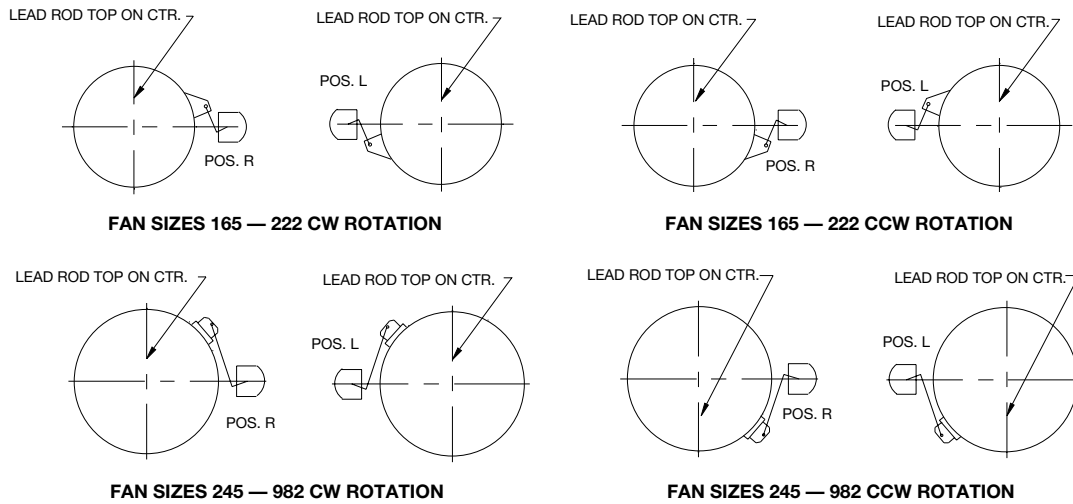

**NOTES:**

- For POS. R:  
CW fan handle down is open.  
CCW fan handle down is closed.

For POS. L:  
CW fan handle down is closed.  
CCW fan handle down is open.

- Handle location on inlet side of fan.
- Reference of AS-13460.

Figure 4. Nested Inlet Vane Handle Location For Non-rotatable Fans

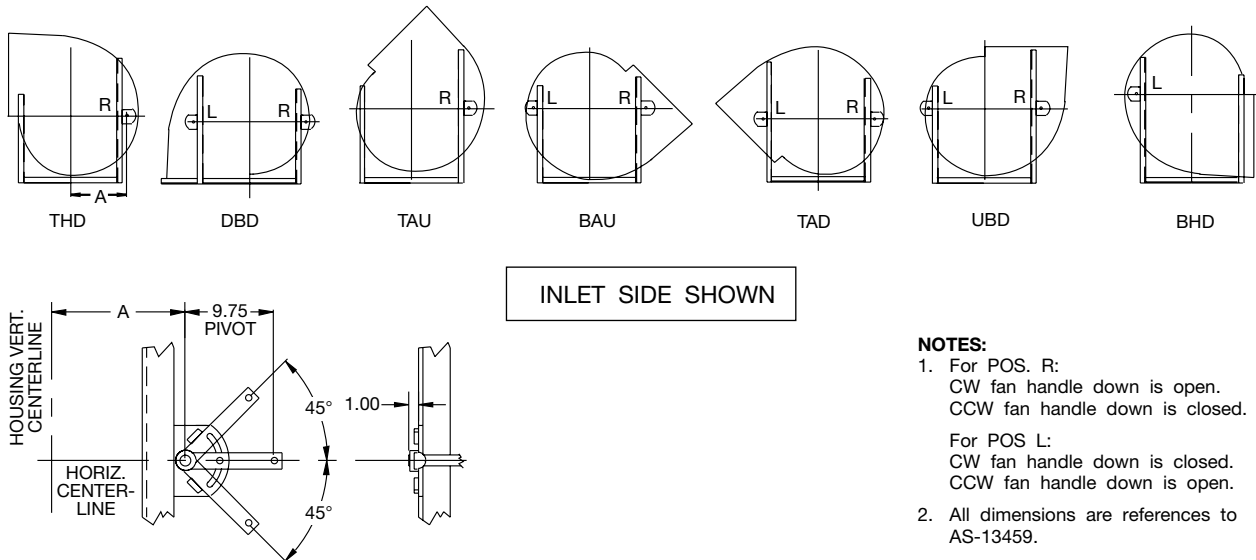

**NOTES:**

- For POS. R:  
CW fan handle down is open.  
CCW fan handle down is closed.

For POS. L:  
CW fan handle down is closed.  
CCW fan handle down is open.

- All dimensions are references to AS-13459.

FAN SIZE	NESTED INLET VANE HANDLE LOCATION							DIMENSION "A"							
	DBD	TAD	THD	TAU	UBD	BAU	BHD	CL 1	CL 2	CL 3	CL 4	CL 5	CL 17	CL 22	CL 26
165	L	L	R	R	R	R	L	12.88	12.88	12.88	12.88	—	—	—	—
182	L	L	R	R	R	R	L	13.75	13.75	14.25	14.75	14.75	—	—	—
200	L	L	R	R	R	R	L	14.75	14.75	15.25	15.75	15.75	—	—	—
222	L	L	R	R	R	R	L	16.38	16.38	16.88	16.88	17.13	—	—	—
245	L	R	R	R	R	L	L	17.50	17.50	18.00	18.00	18.25	—	—	—
270	L	R	R	R	R	L	L	18.75	18.75	19.25	19.75	20.00	19.25	20.00	20.00
300	L	R	R	R	R	L	L	21.25	21.25	21.75	21.75	22.00	21.75	22.00	22.00
330	R	R	R	R	R	L	L	22.75	22.75	23.25	23.50	23.75	23.25	23.50	23.50
365	R	R	R	R	R	L	L	24.75	24.75	25.50	25.50	25.75	25.50	25.50	25.75
402	R	R	R	R	L	L	L	27.00	27.00	27.25	27.25	27.50	27.25	27.50	28.00
445	R	R	R	R	L	L	L	29.00	29.00	29.25	29.75	30.00	29.25	30.00	30.50
490	R	R	R	R	L	L	L	31.50	31.75	31.75	32.50	32.75	31.75	32.50	33.25
542	R	R	R	R	L	L	L	34.25	34.50	34.50	35.25	35.50	34.75	35.25	36.00
600	R	R	R	R	L	L	L	37.50	37.50	38.25	38.25	38.50	38.25	38.50	39.25
660	R	R	R	R	L	L	L	41.00	41.00	41.25	41.75	42.25	41.25	42.25	42.25
730	R	R	R	R	L	L	L	45.00	45.25	45.50	46.00	46.25	45.50	46.25	46.25
807	R	R	R	R	L	L	L	48.75	49.00	49.75	50.00	50.00	49.75	50.00	50.00
890	R	R	R	R	L	L	L	54.50	54.50	55.25	55.50	55.50	55.50	55.50	55.50
982	R	R	R	R	L	L	L	62.25	62.50	58.50	58.75	58.75	58.75	58.75	57.00

Figure 5. Nested Inlet Vane Handle Location For Rotatable Fans

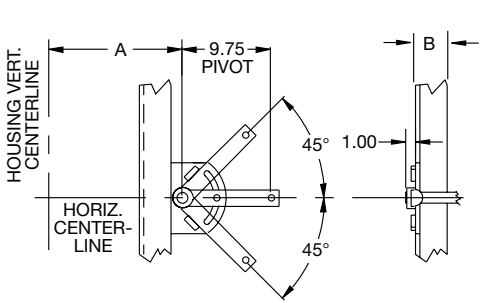
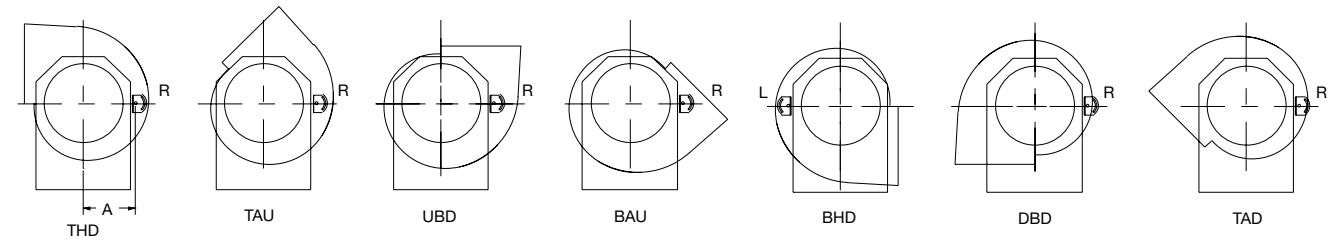

CW ROTATION INLET SIDE SHOWN  
IF DWDI, OPPOSITE DRIVE SIDE.

NOTES:

- For POS. R:  
CW fan handle down is open.  
CCW fan handle down is closed.
- For POS L:  
CW fan handle down is closed.  
CCW fan handle down is open.
- For split housing, consult factory.

FAN SIZE	165	182	200	222	245	270	300	330	365
A	11.25	12.25	13.50	14.62	15.88	17.50	19.06	20.44	22.88
B	1.69	1.69	1.69	2.19	2.19	2.19	2.69	2.69	2.69



TWIN CITY FAN & BLOWER | WWW.TCF.COM

5959 Trenton Lane N | Minneapolis, MN 55442 | Phone: 763-551-7600 | Fax: 763-551-7601